

SPECIFICATIONS

2P4T Slide switch

RATINGS:

16A 125VAC, BA 250VAC [UL, cUL]

BA 250VAC [TV]

CONTACT RESISTANCE:
35mΩ Max.

INSULATION RESISTANCE:
100MΩ at 500VDC

WITHSTAND VOLTAGE:
1,500VAC For 1 Minute

ELECTRICAL LIFE:
>10,000 Cycles

MATERIALS

CASE:
Nylon

KNOB:
Nylon

CONTACTS:
Silver-Nickel Alloy

TERMINALS:
Silver Plated Copper

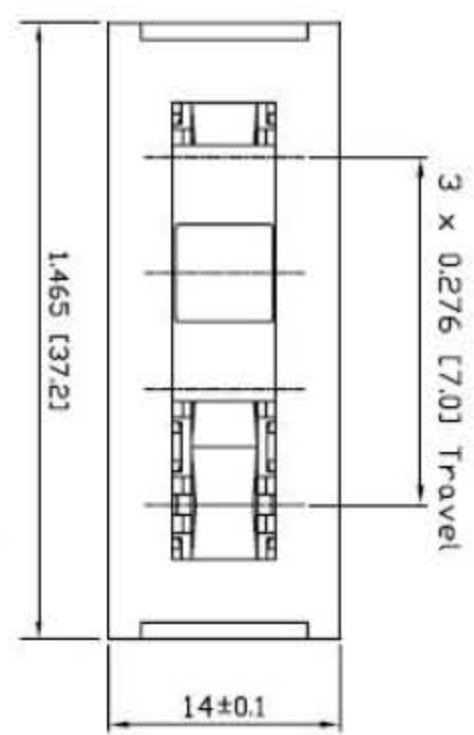
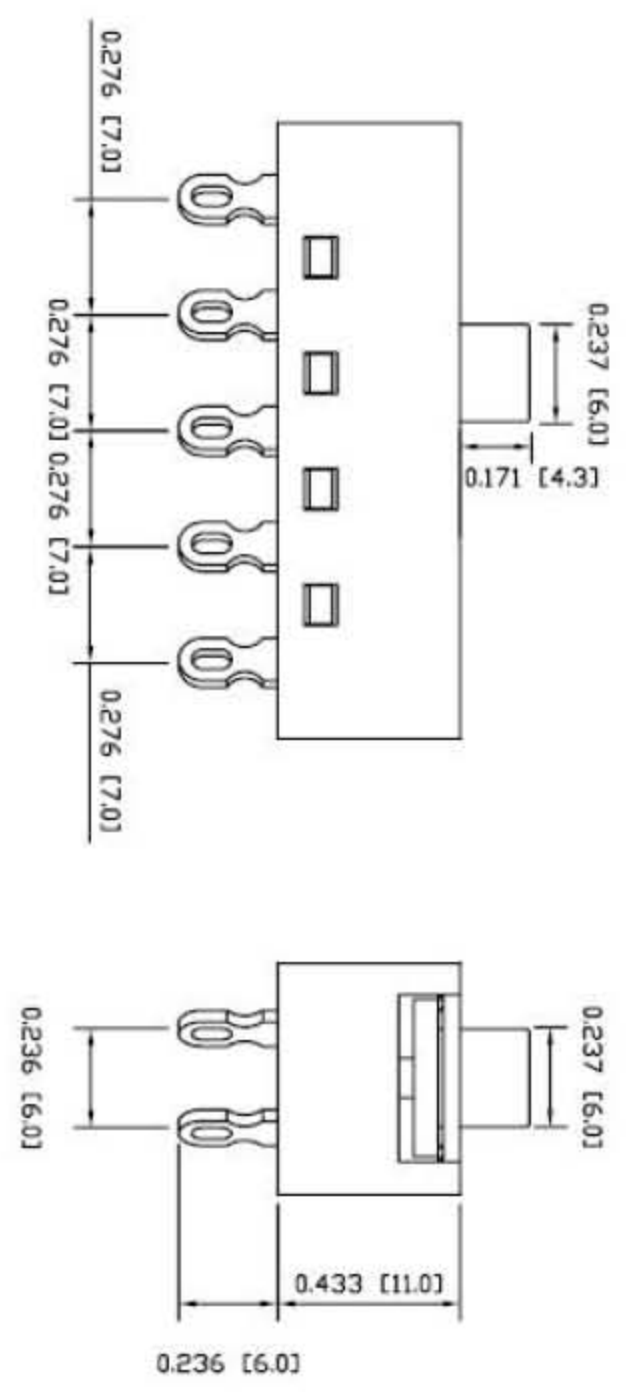

How to Order:

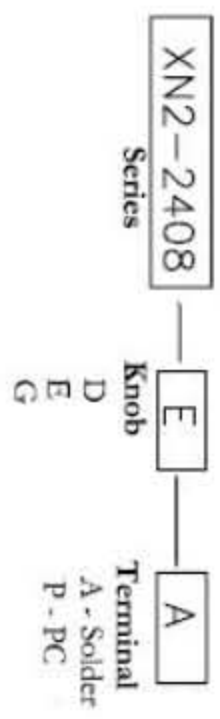

Knob Options:

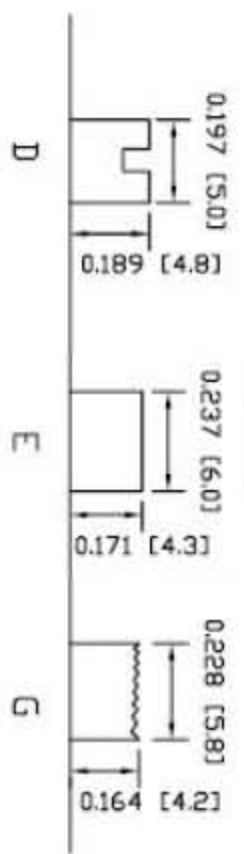

Terminal Option:

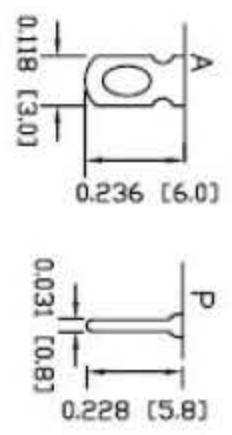

PHASEDA LLC

XN2-24 series

SPECIFICATION SUBJECT TO CHANGE WITHOUT PRIOR NOTICE

DIMENSIONS ARE IN INCHES [MILLIMETERS]

TOLERANCES: DEC. X±0.2

DRAWING NOT TO SCALE

DATE: JAN 2007

8

7

6

5

4

3

2

1

D

C

B

A