

G25 Anti-Vandal Pushbutton

SPECIFICATION:

Rating: 5A 250VAC

Contact Resistance: <50mΩ

Insulation Resistance: > 1,000MΩ

Dielectric Strength: 2,000VAC for 1 minute

Ambient Temperature: -20°C ~ +50°C

Operating Force: 300 - 500gram

Travel Distance: 0.110inch [2.8mm]

Mechanical Life: >500,000 cycles

Electrical Life: >50,000 cycles

MATERIALS:

Body: Stainless steel

Button: Stainless steel

Base: PBT

Contact: Silver alloy

Terminal: Silve plated brass

Panel hole: 0.984" Dia. (Ø25.0mm)

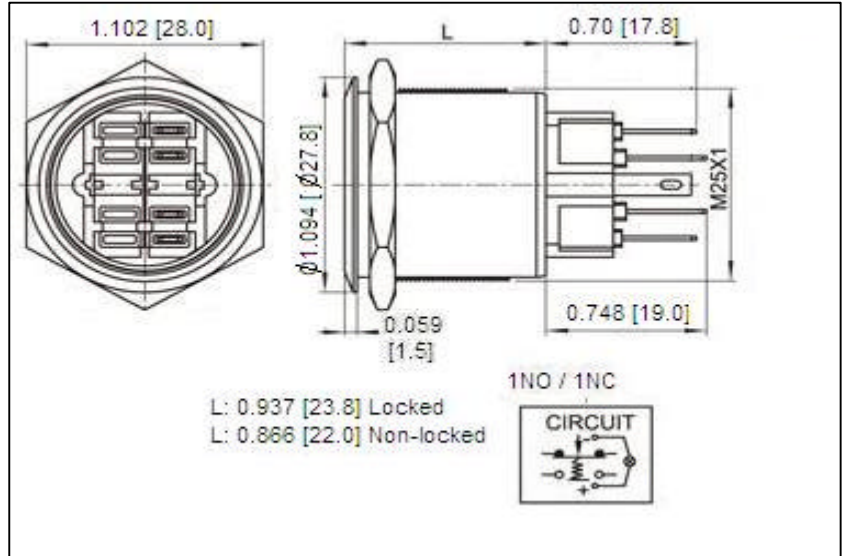

How to Order:

G25	---	K1	---	F	---	R	---	L	---	4	---	2
		Function		Button style		Illumination		LED color		Lamp Voltage		Terminal
		11 - 1NO/1NC (locked)		F - Flat		D - Center dot		N - None		N - none		2- solder
		K1 - 1NO/1NC (non-locked)		D - Dome		R - Circle ring		W -White		1 - 110V		
		K2 - 2NO/2NC (non-locked)		H - High raised		N - none		R - Red		2 - 220V		
		22 - 2NO/2NC (locked)						G - Green		3 - 12V		
								J - Orange		4 - 24V		
								L - Blue		7 - 6V		
										8 - Base		

